

PER COLLEGAMENTI IN SERIE
SERIES CONNECTION OPTIONS
OPTIONALANSCHLUESSEOMAGL
POR CONEXION SERIE
CONEXIONES EN SERIE

PER COLLEGAMENTI IN SERIE
SERIES CONNECTION OPTIONS
OPTIONALANSCHLUESSEOMAGL
POR CONEXION SERIE
CONEXIONES EN SERIE

VISTE DA SOTTO - LATO ATTACCHI
VIEW FROM BELOW - CONNECTIONS SIDE

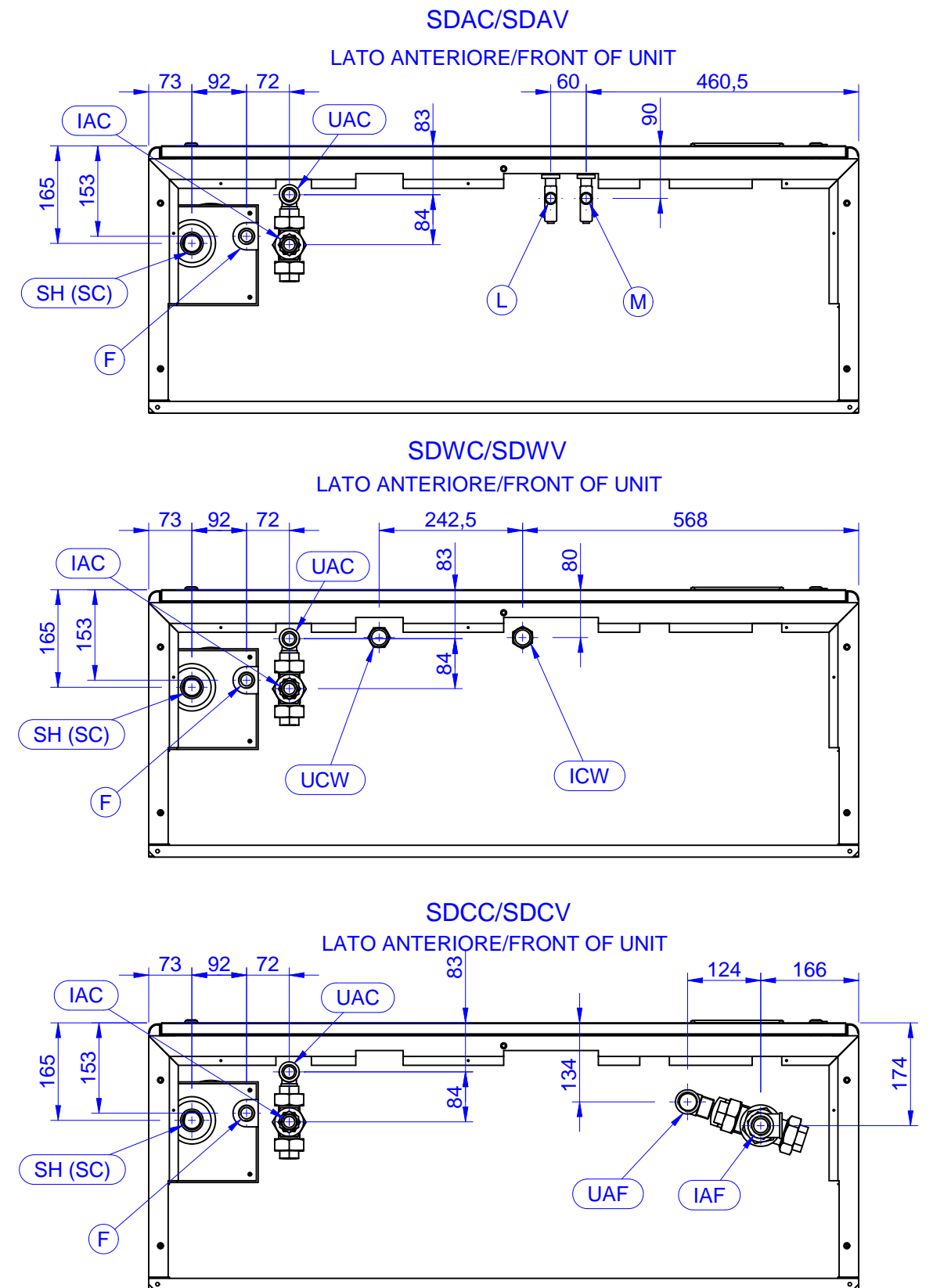

0	PRIMA EMISSIONE FIRST RELEASE	-	-	-	-
Rev.	Descrizione-Description	Dis.-Draftsman	Data-Date	Visto-Checked	N°com.
UNIFLAIR™ Denominazione-Denomination SCHEMA INSTALLAZIONE OVERALL DIMENSIONS		Serie-Series		SDA.-SDW.-SDC.	
		Modello-Model		0501-0601 / 0600	
Scala-Scale -	Foglio-Sheet N. 1/2	Dis.-Draftsman S. Cazzolla	Data-Date 26/04/2010	Disegno-Drawing 06DI0045	Rev. 0

	Italiano	Inglese	Tedesco	Francese	Spagnolo	Attacchi Connections Wasseranschlüsse Conexiones Conexiones
F	ALIMENTAZIONE UMIDIFICATORE	HUMIDIFIER FEEL	WASSERVERSORGUNG	ALIMENTACION DEL HUMECTATOR	ALIMENTACION HUMIDIFICADOR	Ø 6
IAC	INGRESSO ACQUA CALDA	HOT WATER INLET	WARMWASSEREINGANG	ENTREE EAU CHAUDE	ENTRADA DE AGUA CALIENTE	UNI ISO 228/1-G3/4
IAF	INGRESSO ACQUA FREDDA	CHILL WATER INLET	KAELTWASSEREINTRITT	ENTREE EAU FROIDE	ENTRADA DE AGUA FRIA	UNI ISO 228/1-G1
ICW	INGRESSO ACQUA	WATER INLET	WASSEREINGANG	ENTREE EAU	ENTRADA DE AGUA	UNI ISO 228/1-G1 A
L	LINEA LIQUIDO	LIQUID LINE		LIQUIDE DE LIGNE	Línea de líquido	ODS 16
M	LINEA MANDATA	DISCHARGE LINE		LIGNE D'ALIMENTATION	SUMINISTRO DE LÍNEA	ODS 16
PRA	POST-RISC ACQUA CALDA	REHEAT WATER COIL	HEISSWASSERNACHHEIZUNGSREGISTER	POST CHAUFFAGE EAU CHAUDE	POST-CALENDAMENTO POR AGUA CALIENTE	/
SC	SCARICO CONDENSA	CONDENSATE DRAIN	KONDENSATWASSERENTLEERUNG	CONDENSATO DREN	PURGADOR DE CONDENSADOS	Ø 32
SH	SCARICO UMIDIFICATORE	HUMIDIFIER DRAIN	BEFEUCHTERENTFUHLUNG	DREN DE HUMECTATOR	HUMIDIFICADOR DRENAJE	Ø 32
UAC	USCITA ACQUA CALDA	HOT WATER OUTLET	WARMWASSEREAUSGANG	SORTIE EAU CHAUDE	SALIDA DE AGUA CALIENTE	UNI ISO 228/1-G3/4
UAF	USCITA ACQUA FREDDA	CHILL WATER OUTLET	KALTWASSERANSCHLUSS	SORTIE EAU FROIDE	SALIDA DE AGUA FRIA	UNI ISO 228/1-G1
UCW	USCITA ACQUA	WATER OUTLET	WASSEREAUSGANG	SORTIE EAU	SALIDA DE AGUA	UNI ISO 228/1-G1 A

	PESO (Versione completa) WEIGHT (Full Version) GEWICHT (Vollversion) POIDS (version complète) PESO (Versión Completa)
SDAC 0501-0601	200 kg
SDAV 0501-0601	200 kg
SDWC 0501-0601	205 kg
SDWV 0501-0601	205 kg
SDCC 0600	200 kg
SDCV 0600	220 kg

0	PRIMA EMISSIONE FIRST RELEASE	-	-	-	-
Rev.	Descrizione-Description	Dis.-Draftsman	Data-Date	Visto-Checked	N°com.
		Denominazione-Denomination SCHEMA INSTALLAZIONE OVERALL DIMENSIONS		Serie-Series SDA.-SDW.-SDC. Modello-Model 0501-0601 / 0600	
	Scala-Scale -	Foglio-Sheet N. 2/2	Dis.-Draftsman S. Cazzola	Data-Date 26/04/2010	Disegno-Drawing 06D10045
					Rev. 0